

User's Manual
For
ISC02/04/08
Integrated Stepper motor Driver



©2019 All Rights Reserved

Attention: Please read this manual carefully before using the driver.

Table of Contents

1. Introductions and Features.....	1
1.1 Introductions.....	1
1.2 Features.....	1
2. Specifications.....	1
2.1 Electrical Specifications (Tj = 25°C/77°F).....	1
2.2 Operating Environment and other Specifications.....	2
2.3 Mechanical Specifications.....	2
3. Pin Assignment and Description.....	2
3.1 Control Connector Configurations.....	3
3.2 Motor Connector Configurations.....	3
4. Typical application.....	4
5. Interface.....	4
5.1 Supply Voltage.....	4
5.2 Power Supply Selection.....	4
5.3 Output Phase Current.....	5
6. Speed Range Selection.....	5
6.1 High Speed Range.....	5
6.2 Low Speed Range.....	5
6.3 Acceleration Deceleration.....	5
7. Installation.....	6
7.1 NEMA 17 Stepper Installation (without adapting flange).....	6
7.2 NEMA 23 and Larger Stepper Installation (with adapting flange).....	6

1. Introductions and Features

1.1 Introductions

The ISC02 / 04 / 08 is a microprocessor embedded, voltage control, miniature stepper motor controller. It is integrally designed to fit onto stepper motors, and is simple to control. With ISC02 / 04 / 08, the motor speed can be controlled by an analog voltage. It is simple, stable and low cost. ISC02 can provide 0 - 2A adjustable phase current through 10 ~ 28VDC input voltage. ISC04 can provide 1.5 - 4A adjustable phase current through 12 ~ 40VDC input voltage. ISC08 can provide 3 - 8A adjustable phase current through 12 ~ 40VDC input voltage. The microprocessor of the ISC02 / 04 / 08 is capable to ramp up the current speed to the desired speed. It is possible to jump to 1250 rpm in 0.3 seconds. This feature makes the sudden increase of the desired speed become possible. With the ISC02/04/08, the motor speed can be controlled by an external potentiometer. ISC02/04/08 driver can run the motor without user control device. At the same time, with the high-speed current compensation function, ISC02/04/08 can compensate the effects caused by counter electromotive force, which is produced in high-speed motor turning.

ISC02 / 04 / 08 can be mounted onto NEMA 17 / 23 series stepper motor seamlessly through adapting flanges. The enclosure is made of die-cast aluminum which provides a rugged durable protection and improves the heat dissipation.

1.2 Features

- Miniature size 42.3mm*42.3mm*16.5mm
- Integrally designed to fit onto motors seamlessly, as well as work standalone
- All-aluminum precision cast housing, sturdy and durable, good heat dissipation
- Wide range input voltage
- 0 - 2A / 1.5 - 4A / 3 - 8A adjustable output current
- microstep resolutions 3200
- Dual full H-bridge with PWM constant current control
- Self pulse generation, automatic run on power-up
- Speed control through external potentiometer 0.75-1250 RPM
- 0.3 seconds acceleration period
- Switch control run/stop, direction, enable/shutdown
- Automatic current reduction / power saving

2. Specifications

2.1 Electrical Specifications (Tj = 25°C/77°F)

Supply Power	12-40VDC(10-28VDC for ISC02)
Motor Output Current	Max 2A / 4A / 8A per phase (Adjustable through on-board trimmer)
Driving Mode	PWM constant current
Microstep Resolution	3200
Insulation Resistance	>100MΩ
Dielectric Strength	0.5KV in one minute
Speed Range	40 Hz – 67K Hz, 0.75 - 1256 RPM (1.8° Motor)

2.2 Operating Environment and other Specifications

Cooling	Free air
Working Environment	Avoid dust, oil fog and corrosive gases
Working	-40°C - 85°C
Humidity	<80%RH , no condensation, no frosting
Vibration	3G Max
Storage temperature	-50°C - 150°C
Weight	0.1kg

2.3 Mechanical Specifications (unit: mm)

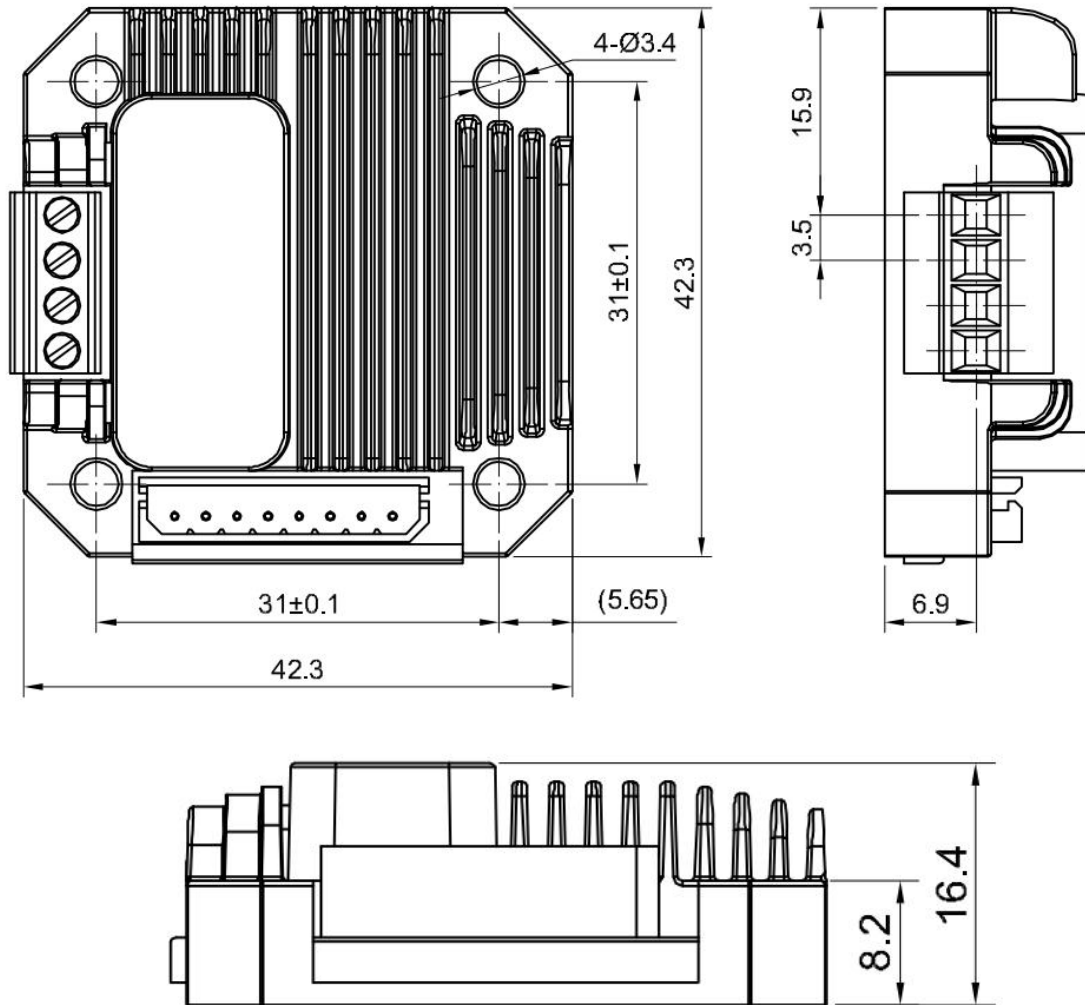

Figure 1: Mechanical specifications

3. Pin Assignment and Description

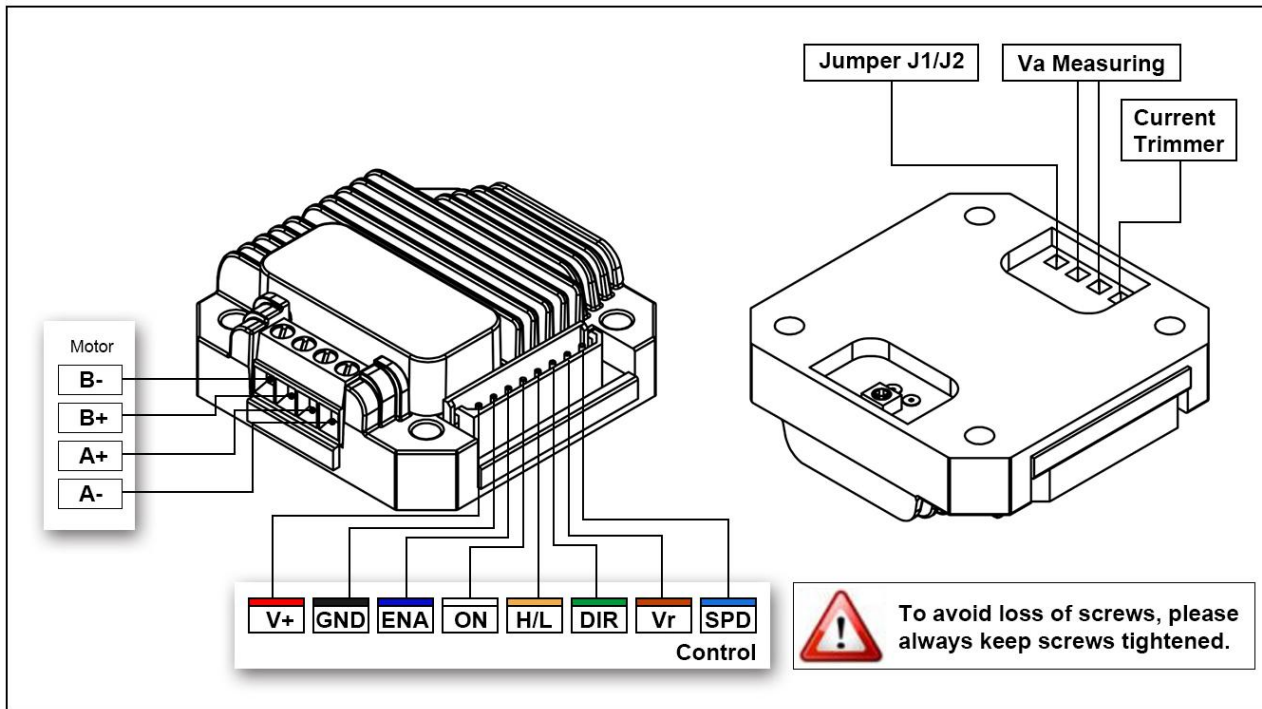

Figure 2: wiring terminal

3.1 Control Connector Configurations

Pin Function	Details
V+	Supply voltage. ISC02: 10 - 28VDC, ISC04 And ISC08:12 - 40VDC.
GND	Supply voltage ground
ENA	Enable/Disable H-bridge. Low-level (shorten to GND): rotor is in free state High-level/dangling: motor is in controlled state
ON	Run/Stop. Low-level (shorten to GND): motor is locked High-level/dangling: motor is in controlled state
H/L	Speed Range selection. Low-level (shorten to GND): low speed High-level/dangling: high speed
DIR	Direction input. Controlled by H / L level. Dangling is regarded as high level.
Vr	5V Reference Voltage output
SPD	Speed Control Voltage input (0.5 – 4.5V)

3.2 Motor Connector Configurations

Pin Function	Details
A+ / A-	Connect to the stepper motor phase A.
B- / B+	Connect to the stepper motor phase B.



Warning: Hot plugging is forbidden.



Warning: All controllers, gateways and subscriber equipments must be common-grounded.

4. Typical application

For users need to use external potentiometer (POT) to control the speed, ISC02/04/08 provides a 5V reference voltage output, and a speed control voltage input port. The resistance of the POT should be between 5K and 10K ohms. Less than 5K will result in excessive power consumption, and larger than 10K will cause inaccurate measurement.

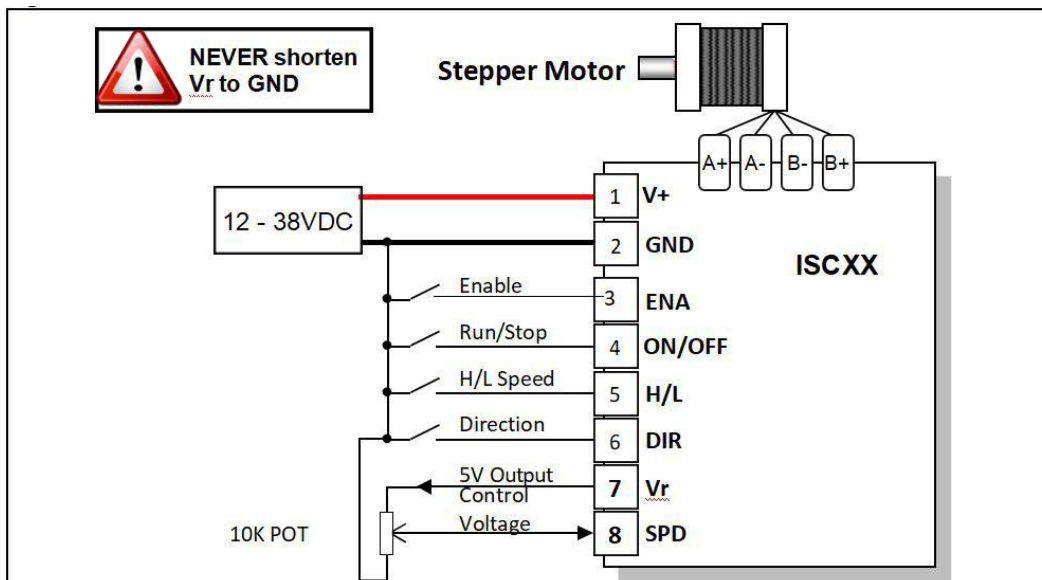

Figure 3: Typical application

Note: The external control range must between -0.3V and 5.3V. Voltage outside the range will only produce smoke.

5. Interface

5.1 Supply Voltage

Because of the design of power supply, ISC02 / 04 / 08 accepts a wide range input voltage. ISC02 controller accepts a wide range input voltage from 10 to 28VDC. ISC04 controller accepts a wide range input voltage from 12 to 40VDC. ISC08 controller accepts a wide range input voltage from 12 to 40VDC.

5.2 Power Supply Selection

ISC02 / 04 / 08 drivers accept a wide range input voltage from 12 to 40VDC. (ISC02 takes 10 - 28 VDC) In general, higher supply voltage improves motor performance under high speed situation, but also increases the power loss and temperature raise.

5.3 Output Phase Current

ISC02 / 04 / 08 is capable of providing a maximum 2A/4A/8A phase output current. In specific application, the peak output current needs to be adjusted to meet the rated motor current. A trimmer (potentiometer) is provided to serve this purpose at the bottom of the controller, as shown in the figure 4.

ISC02: A mapped voltage “Va” of 0 - 4VDC proportionally represents 0 ~ 2A.

ISC04: A mapped voltage “Va” of 1.5 - 4VDC proportionally represents 1.5 ~ 4A.

ISC08: A mapped voltage “Va” of 1.5 - 4VDC proportionally represents 3 ~ 8A.

Please note that , the controller needs to be powered before mapped voltage “Va” can be measured.

Reboot of the controller is required after the setup of the phase current.

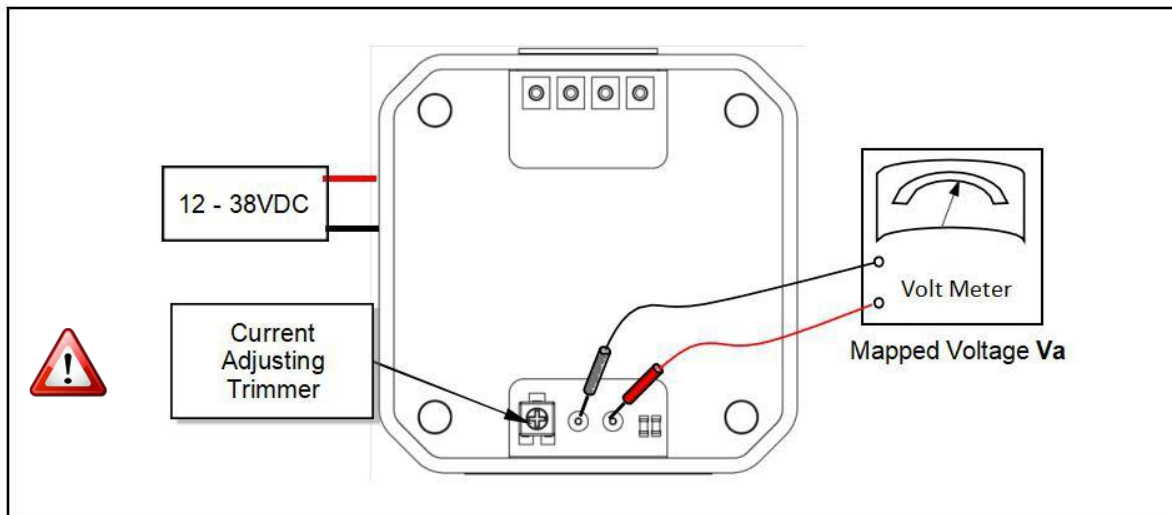

Figure 4: Setup Phase Current

6. Speed Range Selection

To preserve the accuracy of the measurement of the speed control voltage, the user should select the proper speed range. Since the voltage measurement accuracy is 8bit, (ISC02 / 04 / 08 uses a 10bit A/D converter, and abandon the last 2 digits to suppress the noise), the speed adjusting is not continuous, but has an incremental of 1/255 of the max speed. Selecting the proper speed range can improve the accuracy of the speed.

6.1 High Speed Range

When the desired speed is high, the high speed range should be selected, by leaving the terminal 5 open (i. e. , not connected) or linking to 5V.

6.2 Low Speed Range

When the desired speed is low, the low speed range should be selected, by linking the terminal 5 to ground (i. e. , terminal 2).

6.3 Acceleration Deceleration

The microprocessor of the ISC02/04/08 is capable to ramp up the current speed to the desired speed in 0.3 seconds, even when the speed control voltage is changing. This feature makes the sudden increase of the desired speed become possible.

To guarantee the motor can stop as quicker as possible, the deceleration rate is set to infinity, which means the motor will output a desired speed (lower than current speed) immediately.

7. Installation

7.1 NEMA 17 Stepper Installation (without adapting flange)

1. Screw mount ISC controller / driver onto the motor
2. Wire the motor leads.

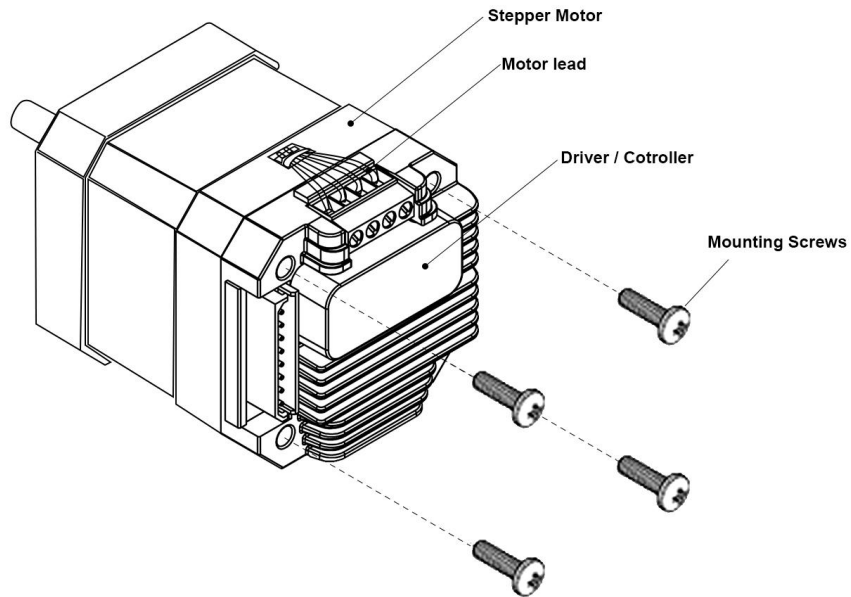

7.2 NEMA 23 and Larger Stepper Installation (with adapting flange)

1. Screw mount the adapting flange onto the motor
2. Screw mount ISC controller / driver onto the adapting flange
3. Wire the motor leads.

