

REV.	REVISION RECORD	BY	DATE
0	ORIGIN	LDJ	6.20.2023

CUSTOMER'S MODEL: NO MODEL
END COVER COLOR: BLACK

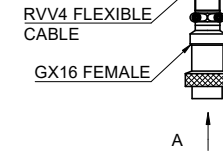
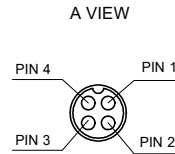
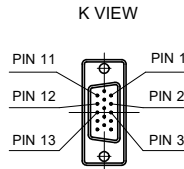
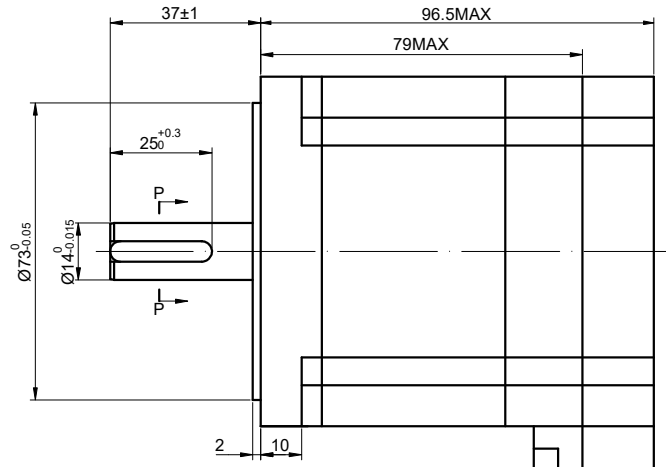
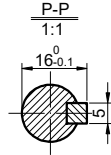
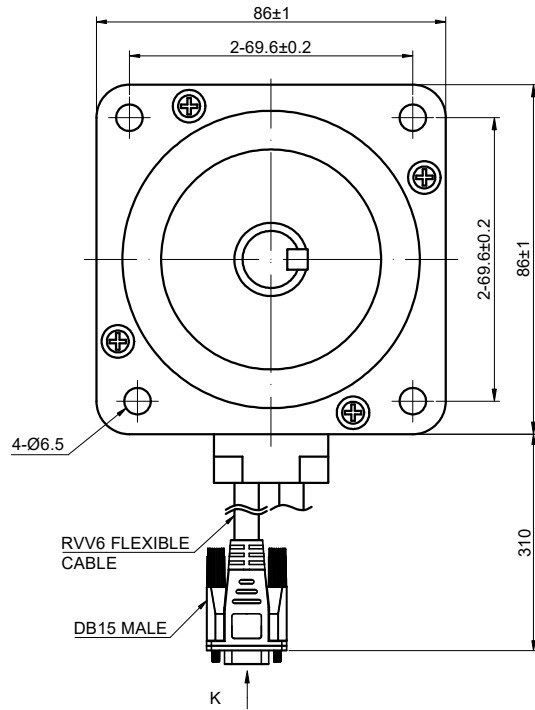

ENCODER RESOLUTION: 1000PPR(4000CPR)

15-PIN DB MALE PLUG	1	2	3	11	12	13
LEAD COLOR	BLK	RED	WHT	YEL	GRN	BLU
DESCRIPTION	EA+	VCC	GND	EB+	EB-	EA-

SPECIFICATION	CONNECTION	BIPOLAR
AMPS/PHASE		6.00
RESISTANCE/PHASE(Ohms)@25°C		0.30±10%
INDUCTANCE/PHASE(mH)@1KHz		2.10±20%
HOLDING TORQUE(Nm)[lb-in]		4.30[38.06]
STEP ANGLE(°)		1.80±5.00%
STEP ACCURACY(NON-ACCUM)		±5.00%
ROTOR INERTIA(g-cm ²)		1400
WEIGHT(Kg)		2.5
AMBIENT TEMPERATURE		-10°C~50°C[14°F~122°F]
INSULATION CLASS		B 130°C[266°F]
TEMPERATURE RISE		MAX.80°C

COMMENT:

- 1.DYNAMIC AXIAL LOAD: 15N MAX
- 2.DYNAMIC RADIAL LOAD @ SHAFT LENGTH 20mm: 75N MAX
- 3.TMBF 6000h OR MORE @ 24V/300RPM
- 4.INSULATION RESISTANCE (NORMAL TEMPERATURE AND HUMIDITY): 100 Mohm
- 5.DIELECTRIC STRENGTH 500VAC FOR 1MIN.(BETWEEN THE MOTOR COILS AND THE MOTOR CASE)

MOTOR CONNECTION		
PIN NO	BIPOLAR	WINDING
1	A+	
2	A-	
3	B+	
4	B-	

FULL STEP 2 PHASE-Ex., WHEN FACING MOUNTING END (X)						DIMENSIONS ARE IN MILLIMETERS.	
STEP	A+	B+	A-	B-	CCW ↓ ↑ CW	THIRD ANGLE PROJECTION	TOLERANCES AS BELOW: DECIMALS ANGLES X ±0.5 ±2° X.X ±0.25 X.XX ±0.13
1	+	+	-	-			
2	-	+	+	-			
3	-	-	+	+			
4	+	-	-	+			

STEPPERMOTOR.FR

STEPPER MOTOR

34HS31-6004D-E1000

THIS DOCUMENT SHALL NOT BE REPRODUCED NOR SHALL THE INFORMATION CONTAINED HEREIN BE USED BY OR DISCLOSED TO OTHERS UNLESS EXPRESSLY AUTHORIZED IN BY WRITING STEPPERONLINE.

SIGNATURE		DATE
DRN	LDJ	6.20.2023
APVD	-	-