

REV.	REVISION RECORD	BY	DATE
0	ORIGIN	LDJ	6.20.2023

CUSTOMER'S MODEL: NO MODEL
 END COVER COLOR: BLACK

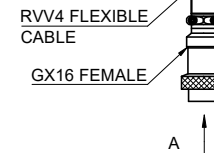
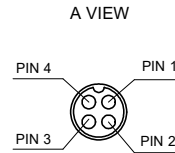
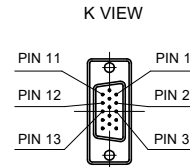
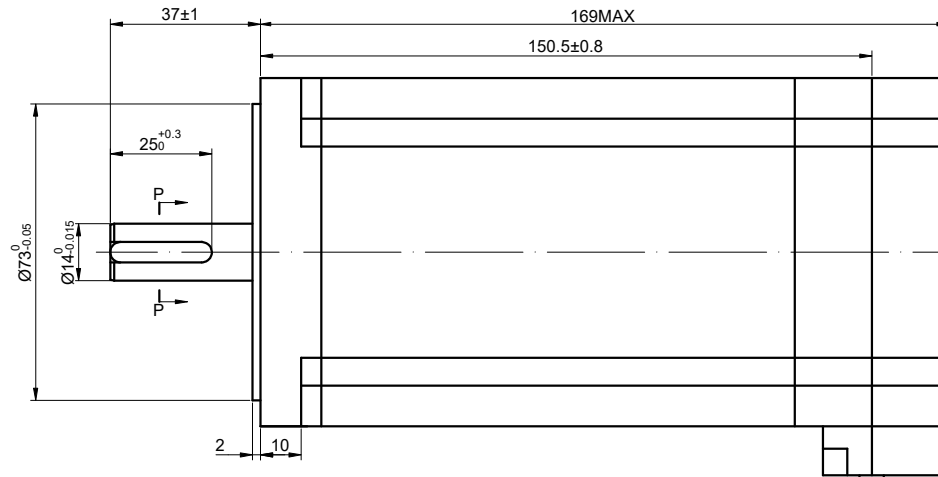
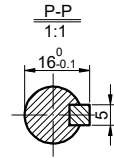
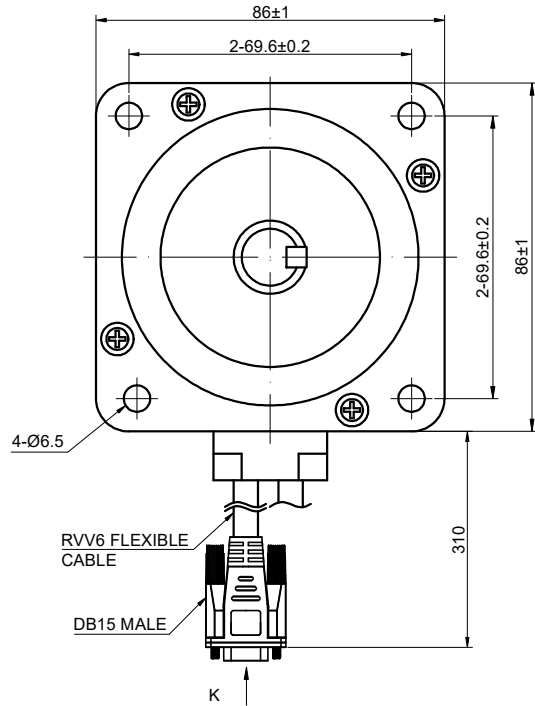

ENCODER RESOLUTION: 1000PPR(4000CPR)

15-PIN DB MALE PLUG	1	2	3	11	12	13
DESCRIPTION	EA+	VCC	GND	EB+	EB-	EA-

MOTOR CONNECTION		
PIN NO	BIPOLAR	WINDING
1	A+	
2	A-	
3	B+	
4	B-	

SPECIFICATION	CONNECTION	BIPOLAR
AMPS/PHASE		6
RESISTANCE/PHASE(Ohms)@25°C		0.62±10%
INDUCTANCE/PHASE(mH)@1KHz		6.60±20%
HOLDING TORQUE(Nm)[lb-in]		12.0[106.29]
STEP ANGLE(°)		1.80±5.00%
STEP ACCURACY(NON-ACCUM)		±5.00%
ROTOR INERTIA(g-cm ²)		3600
WEIGHT(Kg)		5.5
AMBIENT TEMPERATURE		-10°C~50°C[14°F~122°F]
INSULATION CLASS		B 130°C[266°F]
TEMPERATURE RISE		MAX.80°C

COMMENT:

- 1.DYNAMIC AXIAL LOAD: 15N MAX
- 2.DYNAMIC RADIAL LOAD @ SHAFT LENGTH 20mm: 75N MAX
- 3.TMBF 6000h OR MORE @ 24V/300RPM
- 4.INSULATION RESISTANCE (NORMAL TEMPERATURE AND HUMIDITY): 100 Mohm
- 5.DIELECTRIC STRENGTH 500VAC FOR 1MIN.(BETWEEN THE MOTOR COILS AND THE MOTOR CASE)

FULL STEP 2 PHASE-Ex.,WHEN FACING MOUNTING END (X)					
STEP	A+	B+	A-	B-	
1	+	+	-	-	CCW ↓ ↑ CW
2	-	+	+	-	
3	-	-	+	+	
4	+	-	-	+	

DIMENSIONS ARE IN MILLIMETERS.
 TOLERANCES AS BELOW:
 DECIMALS ANGLES
 X ±0.5 ±2°
 X.X ±0.25
 X.XX ±0.13

THIRD ANGLE PROJECTION

STEPPERMOTOR.FR

STEPPER MOTOR

34HE59-6004D-E1000

THIS DOCUMENT SHALL NOT BE REPRODUCED NOR SHALL THE INFORMATION CONTAINED HEREIN BE USED BY OR DISCLOSED TO OTHERS UNLESS EXPRESSLY AUTHORIZED IN BY WRITING STEPPERONLINE.

SIGNATURE		DATE
DRN	LDJ	6.20.2023
APVD	-	-