

END COVER COLOR: BLACK

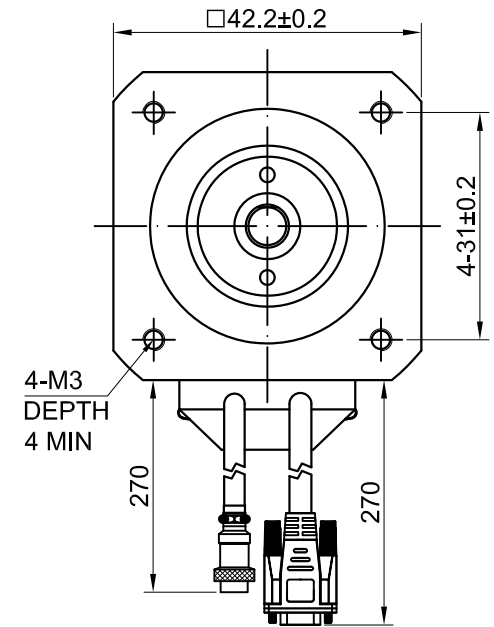

4-PIN GX16 FEMALE PLUG 15-PIN DB MALE PLUG

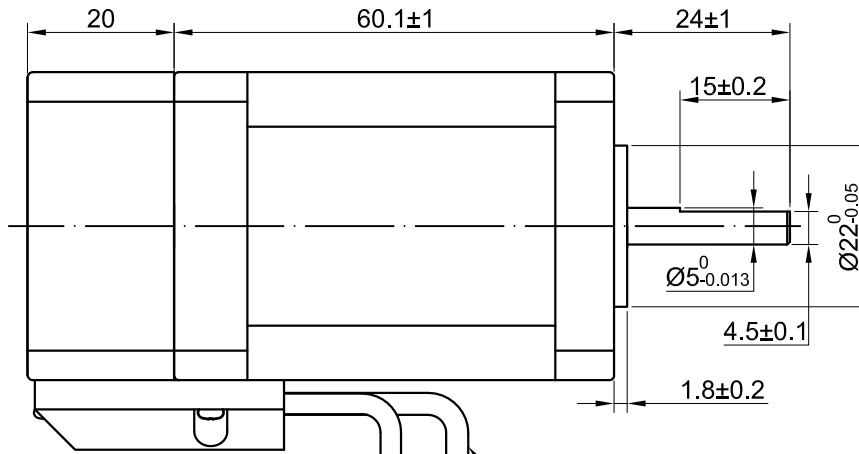
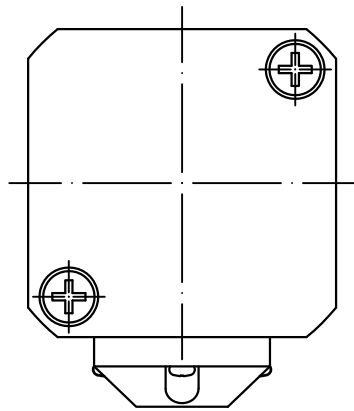
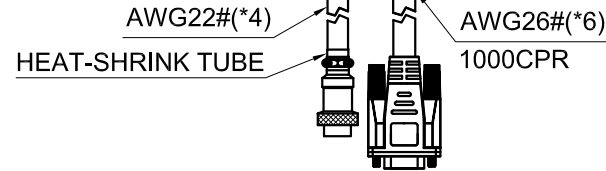
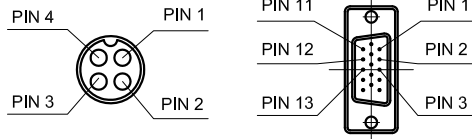

| SPECIFICATION | CONNECTION | BIPOLAR |
|--|------------|-------------|
| AMPS/PHASE | | 2.00 |
| RESISTANCE/PHASE(Ohms)@20°C | | 1.75±10% |
| INDUCTANCE/PHASE(mH)@1KHz | | 4.00±20% |
| HOLDING TORQUE(Nm)[lb-in] | | 0.72 [6.38] |
| STEP ANGLE(°) | | 1.8±0.09 |
| MAXIMUM RADIAL RUNOUT(mm)@LOAD 450g | | 0.025 |
| MAXIMUM AXIAL RUNOUT(mm)@LOAD 920g | | 0.075 |
| ROTOR INERTIA(g-cm²) | | 110 |
| WEIGHT(Kg)[lb] | | — |
| TEMPERATURE RISE:MAX.80°C (MOTOR STANDSTILL;FOR 2PHASE ENERGIZED) | | |
| OPERATION AMBIENT TEMPERATURE 0°C~50°C[32°F~122°F] | | |
| INSULATION RESISTANCE 100 Mohm (UNDER NORMAL TEMPERATURE AND HUMIDITY) | | |
| INSULATION CLASS B 130°C[266°F] | | |
| DIELECTRIC STRENGTH 500VAC FOR 1MIN.(BETWEEN THE MOTOR COILS AND THE MOTOR CASE) | | |

| TYPE OF CONNECTION (EXTERN) | | MOTOR | |
|-----------------------------|---------|-------|---------|
| PIN NO | BIPOLAR | LEADS | WINDING |
| 1 | A+ — | | A+ |
| 2 | A- — | | A- |
| 3 | B+ — | | B+ |
| 4 | B- — | | B- |

FULL STEP 2 PHASE-Ex. ,
WHEN FACING MOUNTING END (X)

| STEP | A+ | B+ | A- | B- | CCW | CW |
|------|----|----|----|----|-----|----|
| 1 | + | + | - | - | | |
| 2 | - | + | + | - | | |
| 3 | - | - | + | + | | |
| 4 | + | - | - | + | | |

ENCODER RESOLUTION:1000PPR(4000CPR)

| 15-PIN DB MALE PLUG | 1 | 2 | 3 | 11 | 12 | 13 |
|---------------------|-----|-----|-----|-----|-----|-----|
| DESCRIPTION | EA+ | VCC | GND | EB+ | EB- | EA- |



| | | |
|-------|-----------|------------|
| APVD | | 10.16.2021 |
| CHKD | | |
| 1:1 | DRN | |
| SCALE | SIGNATURE | DATE |

STEPPER MOTOR

17E1K-07